

AIRMATE

SUBMITTAL DRAWING

- GALVANIZED STEEL CONSTRUCTION
- GANG OPERATED RADIAL BLADES
- ADJUSTMENTS MADE EASILY FROM FACE WITH A SCREWDRIVER
- INCLUDES INTEGRAL SPRING CLIPS FOR INSTALLATION ONTO DUCT COLLAR
- SIZES: 6", 8", 10", 12" AND 14" DIAMETERS
- FINISH: MILL

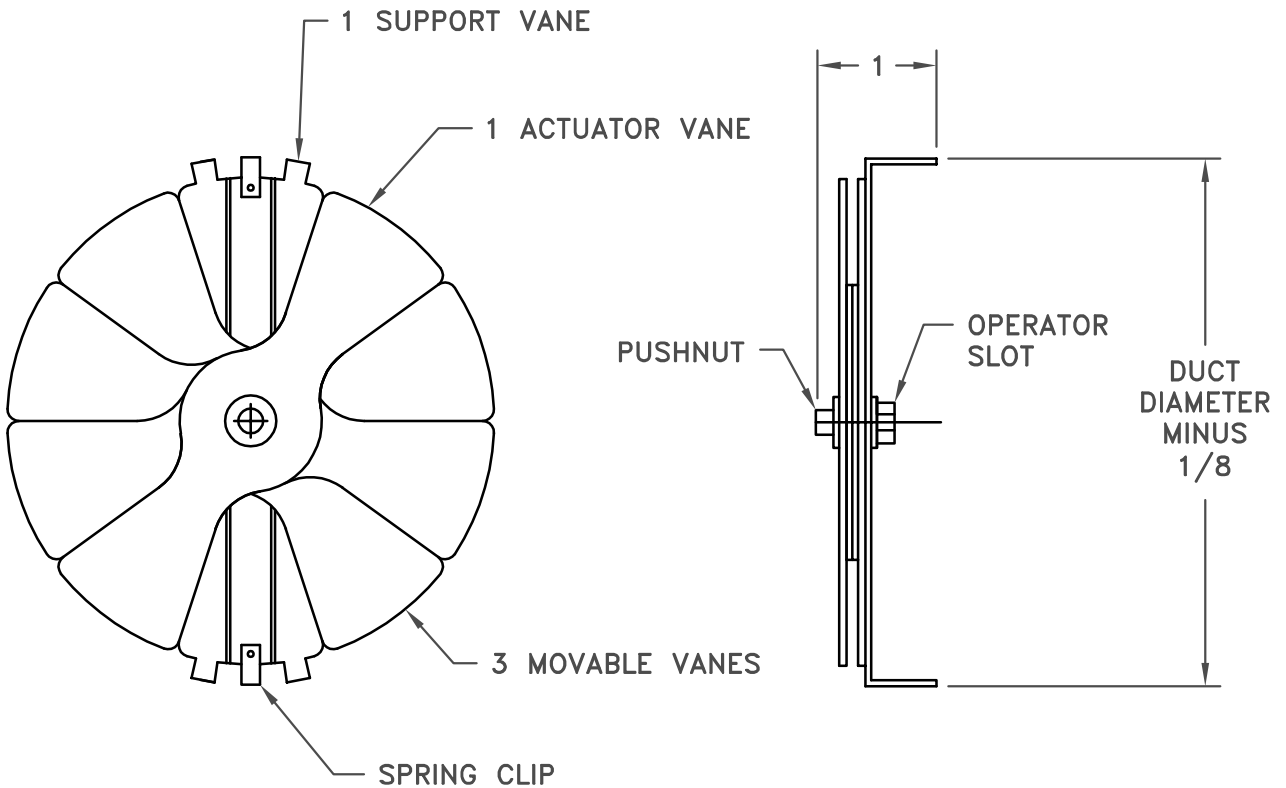

JOB NAME: _____
LOCATION: _____
ARCHITECT: _____
ENGINEER: _____
CONTRACTOR: _____

SUBMITTED BY:

DATE: 11/08/2013

800RD
Radial Blade Damper